

METROLOGY AND MACHINE TOOLS

LABORATORY MANUAL

**B.TECH
(III YEAR – I SEM)
ACADEMIC YEAR 2024 - 25**

Department of Mechanical Engineering



Prepared by
Dr. G. Bala Narasimha
Associate Professor

**MALLA REDDY COLLEGE
OF ENGINEERING & TECHNOLOGY**

(Autonomous Institution – UGC, Govt. of India)

Recognized under 2(f) and 12 (B) of UGC ACT 1956

Affiliated to JNTUH, Hyderabad, Approved by AICTE - Accredited by NBA & NAAC – 'A' Grade - ISO 9001:2015 Certified) Maisammaguda, Dhulapally (Post Via. Kompally), Secunderabad – 500100, Telangana State, India



MALLA REDDY COLLEGE OF ENGINEERING & TECHNOLOGY

(Autonomous Institution – UGC, Govt. of India)

VISION

- ❖ To establish a pedestal for the integral innovation, team spirit, originality and competence in the students, expose them to face the global challenges and become technology leaders of Indian vision of modern society.

MISSION

- ❖ To become a model institution in the fields of Engineering, Technology and Management.
- ❖ To impart holistic education to the students to render them as industry ready engineers.
- ❖ To ensure synchronization of MRCET ideologies with challenging demands of International Pioneering Organizations.

QUALITY POLICY

- ❖ To implement best practices in Teaching and Learning process for both UG and PG courses meticulously.
- ❖ To provide state of art infrastructure and expertise to impart quality education.
- ❖ To groom the students to become intellectually creative and professionally competitive.
- ❖ To channelize the activities and tune them in heights of commitment and sincerity, the requisites to claim the never - ending ladder of **SUCCESS** year after year.

For more information:

www.mrcet.ac.in

MALLA REDDY COLLEGE OF ENGINEERING AND TECHNOLOGY

(Autonomous Institution – UGC, Govt. of India)

www.mrcet.ac.in

DEPARTMENT OF MECHANICAL ENGINEERING **VISION**

To become an innovative knowledge center in mechanical engineering through state-of-the-art teaching-learning and research practices, promoting creative thinking professionals.

MISSION

The Department of Mechanical Engineering is dedicated for transforming the students into highly competent Mechanical engineers to meet the needs of the industry, in a changing and challenging technical environment, by strongly focusing in the fundamentals of engineering sciences for achieving excellent results in their professional pursuits.

QUALITY POLICY

- ✓ To pursuit global Standards of excellence in all our endeavors namely teaching, research and continuing education and to remain accountable in our core and support functions, through processes of self-evaluation and continuous improvement.
- ✓ To create a midst of excellence for imparting state of art education, industry-oriented training research in the field of technical education.

MALLA REDDY COLLEGE OF ENGINEERING & TECHNOLOGY

(Autonomous Institution – UGC, Govt. of India)

www.mrcet.ac.in

DEPARTMENT OF MECHANICAL ENGINEERING

PROGRAM OUTCOMES

Engineering Graduates will be able to:

- 1. Engineering knowledge:** Apply the knowledge of mathematics, science, engineering fundamentals, and an engineering specialization to the solution of complex engineering problems.
- 2. Problem analysis:** Identify, formulate, review research literature, and analyze complex engineering problems reaching substantiated conclusions using first principles of mathematics, natural sciences, and engineering sciences.
- 3. Design/development of solutions:** Design solutions for complex engineering problems and design system components or processes that meet the specified needs with appropriate consideration for the public health and safety, and the cultural, societal, and environmental considerations.
- 4. Conduct investigations of complex problems:** Use research-based knowledge and research methods including design of experiments, analysis and interpretation of data, and synthesis of the information to provide valid conclusions.
- 5. Modern tool usage:** Create, select, and apply appropriate techniques, resources, and modern engineering and IT tools including prediction and modeling to complex engineering activities with an understanding of the limitations.
- 6. The engineer and society:** Apply reasoning informed by the contextual knowledge to assess societal, health, safety, legal and cultural issues and the consequent responsibilities relevant to the professional engineering practice.
- 7. Environment and sustainability:** Understand the impact of the professional engineering solutions in societal and environmental contexts, and demonstrate the knowledge of, and need for sustainable development.
- 8. Ethics:** Apply ethical principles and commit to professional ethics and responsibilities and norms of the engineering practice.
- 9. Individual and teamwork:** Function effectively as an individual, and as a member or leader in diverse teams, and in multidisciplinary settings.

- 10. Communication:** Communicate effectively on complex engineering activities with the engineering community and with society at large, such as, being able to comprehend and write effective reports and design documentation, make effective presentations, and give and receive clear instructions.
- 11. Project management and finance:** Demonstrate knowledge and understanding of the engineering and management principles and apply these to one's own work, as a member and leader in a team, to manage projects and in multidisciplinary environments.
- 12. Life-long learning:** Recognize the need for and have the preparation and ability to engage in independent and life-long learning in the broadest context of technological change.

PROGRAM SPECIFIC OUTCOMES (PSOs)

PSO1 Ability to analyze, design and develop Mechanical systems to solve the Engineering problems by integrating thermal, design and manufacturing Domains.

PSO2 Ability to succeed in competitive examinations or to pursue higher studies or research.

PSO3 Ability to apply the learned Mechanical Engineering knowledge for the Development of society and self.

PROGRAM EDUCATIONAL OBJECTIVES (PEOS)

The Program Educational Objectives of the program offered by the department are broadly listed below:

PEO1: PREPARATION

To provide sound foundation in mathematical, scientific and engineering fundamentals necessary to analyze, formulate and solve engineering problems.

PEO2: CORE COMPETANCE

To provide thorough knowledge in Mechanical Engineering subjects including theoretical knowledge and practical training for preparing physical models pertaining to Thermodynamics, Hydraulics, Heat and Mass Transfer, Dynamics of Machinery, Jet Propulsion, Automobile Engineering, Element Analysis, Production Technology, Mechatronics etc.

PEO3: INVENTION, INNOVATION AND CREATIVITY

To make the students to design, experiment, analyze, interpret in the core field with the help of other inter disciplinary concepts wherever applicable.

PEO4: CAREER DEVELOPMENT

To inculcate the habit of lifelong learning for career development through successful completion of advanced degrees, professional development courses, industrial training etc.

PEO5: PROFESSIONALISM

To impart technical knowledge, ethical values for professional development of the student to solve complex problems and to work in multi-disciplinary ambience, whose solutions lead to significant societal benefits.

CODE OF CONDUCT

1. Students should bring lab Manual/Record for every laboratory session and should enter the readings/observations in the manual while performing the experiment.
2. The group- wise division made in the beginning should be adhered to, and no mix up of students among different groups will be permitted later.
3. The components required pertaining to the experiment should be collected from stores in –charge after duly filling in the requisition form.
4. When the experiment is completed, students should disconnect the setup made by them, and should return all the components/instruments taken for the purpose.
5. Any damage to the apparatus that occurs during the experiment should be brought to the notice of lab in-charge, consequently, the cost of repair or new apparatus should be brought by the students.
6. After completion of the experiment, certification of the concerned staff in –charge in the observation book is necessary.
7. Students should be present in the labs for the total scheduled duration.
8. Students should not carry any food items inside the laboratory.
9. Use of cell phones and IPODs are forbidden.
10. Students should not write on or deface any lab desks, computers, or any equipment provided to them during the experiment.
11. Every student should keep his/her work area properly before leaving the laboratory.

MALLA REDDY COLLEGE OF ENGINEERING & TECHNOLOGY
III Year B. Tech ME - I SEM

(R22A0385) METROLOGY AND MACHINE TOOLS LAB

COURSE OBJECTIVES:

1. To learn about basic measuring instruments vernier callipers, screw gauge, vernier height gauge.
2. To learn the measurement of the Angle and taper's by Bevel protractor, Sine bar, etc.
3. To learn about Mechanical parameter measuring systems and different alignment techniques.
4. To understand the working principles of various machines viz lathe, Drilling, milling, shaping.
5. To understand the usage of CNC in Lathe and Milling machines.

CYCLE-1

1. Measurement of lengths, heights, diameters by vernier calipers, micrometers etc.
2. Measurement of bores by internal micrometers and dial bore indicators.
3. To Study the Angle and taper measurements by Bevel protractor, Sine bars, etc.
4. Measurements by Gear Tooth Vernier Calipers.
5. To study about the Tool makers microscope and its application
6. Surface Roughness Measurement

CYCLE-2

1. Introduction of general-purpose machines -Lathe, drilling machine, Milling machine, Shaper, Planning machine, slotting machine, Cylindrical Grinder, surface grinder and tool and cutter grinder.
2. To perform Step turning and taper turning on lathe machine
3. To perform Thread cutting and knurling on lathe machine.
4. To perform spur gear cutting using milling machine.
5. To perform flat surface operation on a block using shaper.
6. To perform Drilling & Tapping operations.
7. To perform precise surface grinding operations.
8. To perform precision cylindrical grinding operations.
9. To perform splines on a block using slotting machine.
10. To perform step turning operation using CNC lathe.

COURSE OUTCOMES:

Students get exposure to

1. Apply the procedures to measure length, width, depth, bore diameters, external tapers, tool angles, and surface roughness by using different instruments.
2. Demonstrate knowledge of different machine tools used in machine shops.
3. Perform step, taper turning, knurling and threading operations on lathe.
4. Practical exposure on Flat Surface machining, Shaping, Slotting, Milling and grinding operations.
5. Develop programs on CNC lathe and Milling machines.

SAFETY PRECAUTIONS:

1. Attention to be paid for clamping the job, tool, tool holders or supporting items.
2. Care should be taken for avoiding accidental contact with revolving cutters.
3. Break the sharp edges in jobs
4. Do not handle chips with bare hands, use brush or hand gloves.
5. Pay attention while selecting tools or blades for the proposed use to avoid accidents.
6. Do not remove chip while machine is running.
7. Ensure proper bucking of m/c slides or pay attention or alertness.
8. Care should be taken while selecting rapid or feed .
9. Follow safety precautions while approach with cutter to avoid tool damage.
10. Use coolants for heat dissipation.
11. Use goggles for sparks, spatters, avoid the watch clearly with bare eyes.
12. Avoid sharp edge tools.
13. Ensure clamping on surface grinding m/c before take a cut.
14. Select proper speed or feed or depth of cut.
15. Aim for easy chip disposal system.

PROBABLE ACCIDENTS:

1. Before switching on any machine tool, work piece, tool or tool holder or any supporting assembly like tailstock in lathe to be clamped properly.
2. The chief hazard associated is accidental contact with moving cutter
3. Hazard of sharp edge contact with chips while machining.
4. Selection of no. of teeth or blade size on primer hacksaw machine.
5. Ramming of chips when machine in motion viz. shaping or slotting.
6. Locking of tables and ensure the feed.
7. Switch on the connection selection of lever (rapid/feed).
8. Approach the tool to the work piece while machining at slow pace to avoid cutting tool damage.
9. Flying sparks in welding.
10. Holding of heated parts after machining, welding or spot welding.
11. Magnetic clamping refines starting the surface grinding.
12. Selection of proper depth cut or feeds or any machine.
13. Chip disposal system to the accident fre

EXPERIMENT 1

MEASUREMENT OF LENGTHS, HEIGHTS, DIAMETERS BY VERNIER CALIPERS MICROMETERS ETC.

AIM:

The objective is to familiarize students with the use of vernier calipers, Micrometer screw gauges. The write –up for this experiment will be submitted at the end of the laboratory period. Drawings of the parts to be measured in the lab are available from the Teaching Assistant for the purposes of dimensioning. No aids other than calculators are allowed to be used.

THEORY:

Least Count – the smallest degree by which two measurements may be differentiated with a particular instrument; generally considered to be of the same order as the smallest division in the instruments' scale.

The Least Count is a measure of the accuracy of a measuring instrument.

VERNIER CALLIPERS:

A vernier caliper consists of a rule with a main engraved scale and a movable jaw with an engraved vernier scale. The main scale is calibrated in centimeters (cm) with a millimeter (mm) least count, and the movable vernier scale that divides the least count on the main scale into 50 equal sub-divisions. The span of the upper jaw is used to measure the inside diameter of an object such as hollow cylinders or holes. The leftmost mark on the vernier scale is the zero mark, which is often unlabeled. The measurement is made by closing the jaws on the object to be measured and reading where the zero mark on the vernier scale falls on the main scale. The first two significant figures are read directly from the main scale. This is known as the main scale reading.

The next significant figure is the fractional part of the smallest subdivision on the main scale (in this case, mm). If a vernier mark coincides with a mark on the main scale, then the mark number is the fractional part of the main scale division. Before making a measurement, the zero of the vernier caliper should be checked with the jaws completely closed. It is possible that the caliper not being properly will produce systematic error. In this case, a zero correction must be made for each reading. The least of the vernier caliper is calculated by equation

A large range of measurements can be made using the one measuring device. Against The majority of vernier calipers do not provide sufficient accuracy for close tolerance measurements.

In the machining process, we use vernier callipers or a micrometer for taking measurements. General analog vernier calipers can measure with the minimum unit of 1/20 mm. Several types of digital vernier calipers can measure with the minimum unit of 1/100mm.

Least Count = Value of the smallest division on main scale / Number of divisions on vernier scale

2) Measurement = Main scale reading + coinciding vernier scale division \times Least count

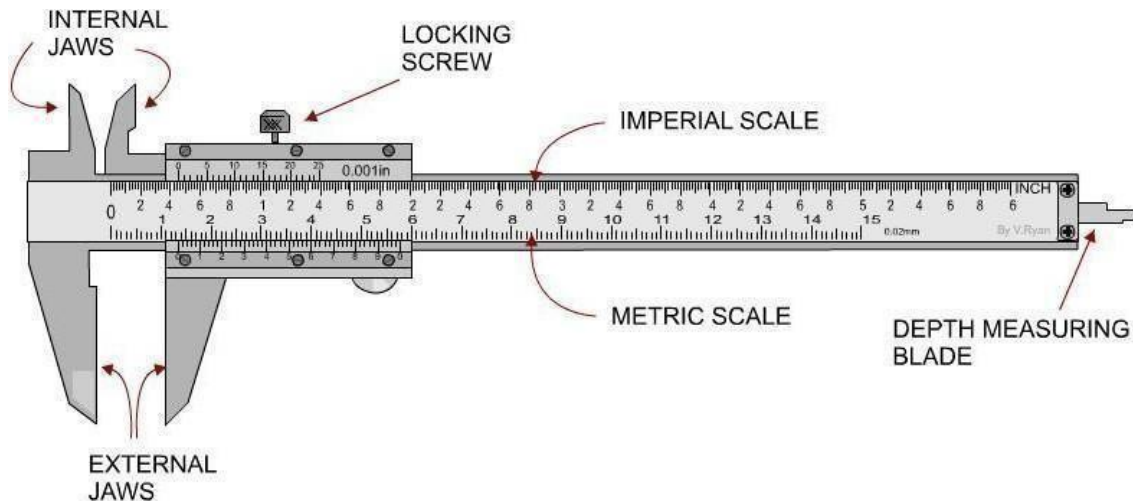

PROCEDURE:

Least Count: Least count is the minimum distance which can be measured accurately by the instrument. Least Count of Vernier Caliper is the difference between the value of main scale division and Vernier Scale Division.

Thus Least Count = (Value of Smallest Division on Main Scale) - (Value of Smallest Division on Vernier Scale) = $1 - 49/50 = 0.02$ mm. (or) Least Count = (Value of Minimum Division on the Main Scale) / (Number of Division on Vernier Scale) = $1/50 = 0.02$ mm

The given component is fixed between the jaws firmly, i.e., in between fixed jaw and movable jaw.

The reading is to be noted down. Procedure for taking the Reading:

1. After closing the jaws on the work surface, take the readings from the main as well as Vernier Scale. To obtain the reading, the number of divisions on the main scale is first read off.

The Vernier Scale is then examined to determine which of its divisions coincide or most coincident with a division on the main scale.

2. Before using the instrument should be checked by zero error. The zero line on Vernier Scale

should coincide with zero on the main scale.

3. Then take the reading in mm on main scale to the left of zero on sliding scale.
4. Now Count the no. of divisions on Vernier Scale from zero to a line which exactly Coincides with any line on the main scale.

Thus total reading = [Main scale reading] + [No. of divisions with a division on Main Scale] X Least Count. (OR) $TR = MSR + VC \times LC$

5. Take the reading for 4 times.

OBSERVATIONS :

S. No	MSR	VSR	Total Reading= MSR+ (VSR X LC)

MICROMETER SCREW GAUGE:

THEORY:

A micrometer consists of a movable spindle (jaw) that advances toward another parallel-faced jaw, called an anvil, by rotating the thimble. The thimble rotates over an engraved sleeve or barrel that is mounted on a solid frame. Most micrometers are equipped with a ratchet, at the far right in figure 2, which allows slippage of the screw mechanism when a small constant force is exerted on the jaw. This permits the jaw to be tightened on an object with the same amount of force each time. The axial main scale on the sleeve is calibrated in mm and the thimble scale is the vernier scale and is usually divided into increments of 0.01mm.

The pitch of a screw is the distance between two consecutive screw threads and is the lateral linear distance the screw moves when turned through one rotation. The axial line on the sleeve main scale serves as a reading line. If a micrometer does not have 0.5 mm divisions on the main scale, you must determine whether the thimble is in its first rotation or second. If it has 50 divisions on the thimble and completes 1 mm in two rotations, each division on the thimble gives 0.01 mm.

1. Measurements are taken by noting the reading x on the main scale of the sleeve. Note the position of the edge of the thimble on the main scale and the position of the reading line on the thimble scale.

2. Multiply this reading with 0.01 mm and add to x
3. Least Count = Pitch (Distance between two consecutive threads of screw) ÷ Number of divisions on thimble scale
4. Measurement = Main scale reading + coinciding thimble scale division × Leastcount

How to Use a Micrometer

When close tolerances are required, measurements are taken with a micrometer due to its superior accuracy over a vernier caliper. The micrometer as can measure with the minimum unit of 1/1000mm.

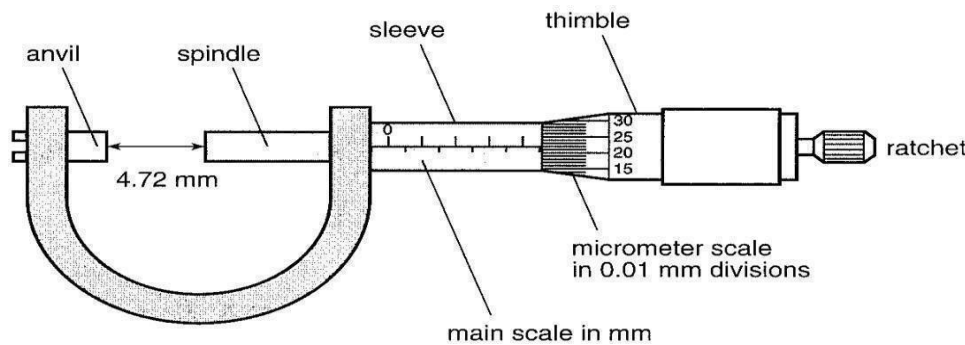

PROCEDURE:

- The work piece is held between the 2 anvils without undue pressure.
- This is Accomplished by having a ratched drive to turn the thimble when the anvils contact each other directly or indirectly through work piece placed in between the ratchet tips over the screw cap without moving the screw forwards and thus avoids undue pressure.
- Least Count = Pitch of the screw/ No. of Divisions on Circular Scale. If Pitch of screw is mm and Circular Scale has 50 divisions on it, then Least Count = 0.5 / 50 ~ 0.01mm
- In measuring, the dimension of work piece the main scale upto the leveled edge of thimble and no. of divisions of thimble scale to axial line on barrel are observed addition of two given result.

OBSERVATIONS:

S.No	PSR	HSR	PSR+(HSR×LC)	READINGS

RESULTS:

The specifications of the given component are measured with vernier caliper, outside micrometer & bore dial gauge.

ADVANTAGES OF VERNIER CALIPER

- Vernier Calipers are precision measuring instruments with a higher accuracy level.
- ☐ ➤ It is one of the best caliper to measure least count of any object. However there are certain number of advantages and disadvantages about these instruments which are discussed below.
- ☐ ➤ Vernier Caliper is very important tool in manufacturing industry and has lot of benefits. Precision & accuracy are two hallmarks of Vernier calipers, this instrument has robust tendency to give precise and accurate measurements of various dimensions.
- ☐ ➤ **Twin Scales:**
 - Main or primary scale and Vernier or secondary scale are constructed together into the measuring equipment, an additional measuring gadget like a ruler or tape measure is not needed.
- ☐ ➤ **Adaptability for Measurements:**
 - Vernier calipers can be used for variety of applications. It can measure inner, outer, steps and depth dimensions of any geometrical objects.
- ☐ ➤ **Strength:**
 - Majority of manufacturers make Vernier calipers by using pure stainless steel to give strength and durability. As we know stainless steel have a higher strength & corrosion protection and hence by following standard manufacturing processes, Vernier Calipers can sustain for a life time.
- ☐ ➤ **Price:**
 - Vernier calipers are very common, there are many suppliers available in the market. Therefore the prices are very competitive now and these are readily available in cheap prices as well.

DISADVANTAGES OF VERNIER CALIPER

- ☐ Good Vision Is Needed:

As quite evident, the Vernier scale of a Vernier caliper is significantly small component. With improper vision or improper angle of vision it is quite difficult to properly read or identify measurements. To avoid such mistakes normally Good vision or a right light with magnifying glass would be recommended while taking readings.

Learning A Vernier Caliper:

All of us know that the Vernier scale is a specialized precision measuring tool; user should make an effort to learn how to read from a Vernier caliper before going to take measurements.

Prospect Of Errors:

While acquiring several numbers of measurements, user might end up committing error. To avoid this prospect of errors extra attentiveness is needed.

Availability Of Alternates:

Digital calipers are best alternate to Vernier calipers that can yield more accurate values with no prospect of errors as in manual Vernier Calipers

ADVANTAGES OF MICROMETER:

More accurate than rules. Greater precision than calipers. No parallax error

Relatively inexpensive. End measurement

DISADVANTAGES OF MICROMETER:

Short measuring range End measurement only Single purpose instrument.

Limited wear area of anvil and spindle tip.

APPLCATIONS:

It can be used to measure diameter of a wire, thickness of a thin metal sheet, etc

These instrument are used to check round work pieces accurately. It is also used to check wall

thickness of the pipe.

VIVA-QUESTIONS:

- 1. What is the least count of a Vernier caliper having 20 divisions on Vernier scale, matching with 19 divisions of main scale?
- 2. What type of micrometer is used for measuring longer internal length? How to maintain constant pressure in micrometer?
- 3. What is the purpose of adjusting nuts in a micrometer? What is the range of dial bore gauge?
- 4. What is the least count of a vernier caliper?
- 5. Explain briefly about the different types of micrometers?
- 6. What is the least count of a micrometer and how is it determined? What are Vernier Calipers?
- 7. What is Micrometer?
- 8. What is the Least Count of Vernier & Outside Micrometer? What are applications of Vernier & Outside Micrometer? What are the errors in Vernier & Outside Micrometer? Compare Vernier & Outside Micrometer .
- 9. What are the precautions required during use of inside micrometer & dial Bore indicator.
- 10. Which one is more precise when compared to inside micrometer & dial bore indicator. What are the applications of inside micrometer & dial bore indicator?
- 11. How do you find the least count of inside micrometer?

EXPERIMENT 2

MEASUREMENT OF BORES INTERNAL MICROMETERS AND DIAL BORE INDICATORS.

AIM:

The objective is to familiarize students with the use of vernier calipers, Micrometer screw gauges. The write-up for this experiment will be submitted at the end of the laboratory period. Drawings of the parts to be measured in the lab are available from the Teaching Assistant for the purposes of dimensioning. No aids other than calculators are allowed to be used.

THEORY:

Least Count – the smallest degree by which two measurements may be differentiated with a particular instrument; generally considered to be of the same order as the smallest division in the instruments' scale.

The Least Count is a measure of the accuracy of a measuring instrument.

BORE DIAL GAUGE:

THEORY:

It is used for measuring internal diameter of a hole, which is machined. The bore dial gauge consists of one fixed measuring head and one movable measuring head. The movement of the movable measuring rod is transmitted to dial indicator by push rod through a spring actuated hinged member. Thus the horizontal movement of the rod is transmitted into vertical direction gives indication of variation of size. The calibrated rods are made in different sizes and sometimes number of short rods threaded at the ends are used in combination to get different desired lengths

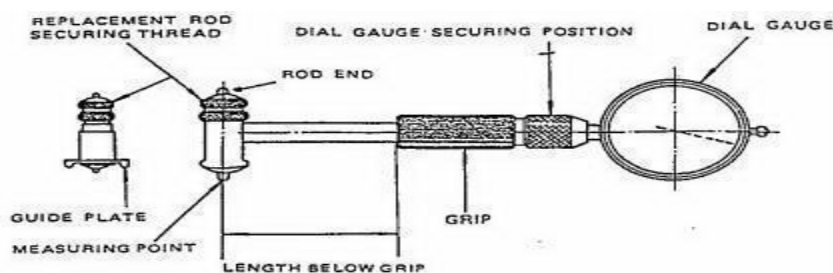

PROCEDURE:

The measuring head is placed in contact with the surface of hole & movement of measuring head contact point is transmitted to the amplifying mechanism by the calibrated rods and its shown on the dial indicator. These calibrated rods are located in tabular supports between the head and dial units. The readings from dial indicator are tabulated

OBSERVATIONS:

S.NO	DIAMETER	TRIAL	TRIAL	AVERAGE	MEASURED
		1	2		DIAMETER

Note: Please avoid dropping the tools as this can lead to irreparable damage to the precision instruments. The tools are coated with a light film of oil to prevent corrosion. Please do not remove this oil. A cloth has been provided to clean your hands after use.

RESULTS:

The specifications of the given component are measured with vernier caliper, outside micrometer & bore dial gauge.

VIVA-QUESTIONS:

1. What are the precautions required during use of inside micrometer & dial Boreindicator.
2. Which one is more precise when compared to inside micrometer & dial boreIndicator.
What are the applications of inside micrometer & dial bore indicator?
3. How do you find the least count of inside micrometer?
4. What are the other instruments for measuring bores?

EXPERIMENT NO. 3

ANGLE MEASUREMENT USING BEVEL PROTRACTOR & SINE BAR

AIM: To Study the Angle and taper measurements by Bevel protractor, Sine bars, etc.

INSTRUMENTS USED:

- 1. Sine bar 2. Work piece 3. Dial Gauge 4. Slip gauges 5. BevelProtractor.

SINE BAR:

THEORY:

The sine principle uses the ratio of the length of two sides of a right triangle in deriving a given angle. The accuracy with which the sine principle can be put to use is dependent in practice, on some form of linear measurement. The sine bar in itself is not a complete measuring instrument. Sine bars in conjunction with slip gauges constitute a very good device for the precise measurement of angles. The arrangement is based on the fact that for any particular angle θ the sides of a right angled triangle will have precise ratio, i.e,

$$\sin\theta = \frac{h}{l}$$

If h and l could be measured accurately, θ can be obtained accurately. The value of h is built-up by slip gauges and value l is constant for a given sine bar.

Sine bars are used either to measure angles very accurately or for locating any work to a given angle within very close limits. Sine bars are made from high carbon, high chromium, corrosion resistant steel, hardened, ground and stabilized. Two cylinders of equal diameter are attached at the ends. The axes of these two cylinders are mutually parallel to each other and also parallel to and at equal distance from the upper surface of the sine bar. The distance between the axes of the two cylinders is exactly 100, 200 and

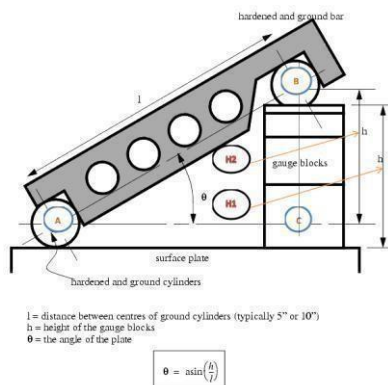

(ii) To check unknown angles:

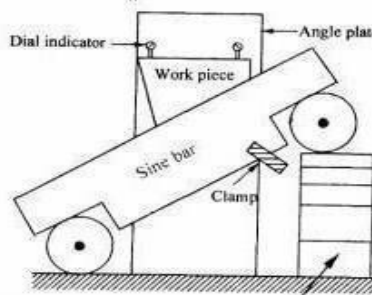

PROCEDURE:

1. Place the work piece/wedge above the sine bar and make it horizontal with the base.
2. The dial gauge is then set at one end of the work moved along the upper surface of the component.
3. If there is any variation in parallelism of the upper surface of the component and the surface plate, it is indicated by the dial gauge.
4. The combination of the slip gauges is so adjusted that the upper surface is truly parallel with the surface plate.
5. Note down the values of the slip gauges.
6. Calculate the angle using the formula.

-1

$$\theta = \sin^{-1}(h/l)$$

7. Repeat the procedure 3 or 4 times and take the average.

OBSERVATIONS:

S.No.	HEIGHT(h)	LENGTH(l)	ANGLE

BEVEL PROTRACTOR:

A universal bevel protractor is used to measure angles between two planes. This consists of stem, which is rigidly attached to main scale and a blade, which is attached to the Vernier scale and can be rotated to read angles. To improve the accessibility, the blade can also slide.

The least count is calculated by knowing the value of the smallest division on the main scale and number of division on the Vernier scale. It should be noted that the divisions on the main scale is in degrees and that the fractional divisions of degrees are minutes (i.e. with 60 minutes/degree, denoted). To measure angle between two planes, rest the stem on one of the planes (reference plane). Rotate the blade such that blade is flush with second plane. Readings are taken after ensuring that the stem and blade are in flush with the two planes. Lock the protractor at this point and note down the readings.

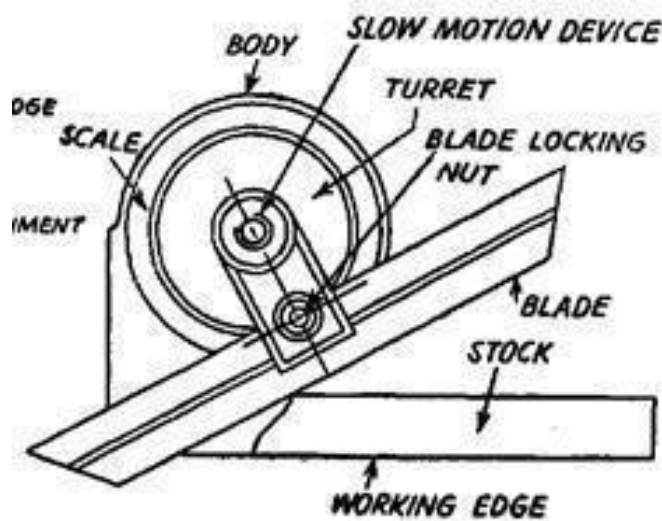

OBSERVATIONS:

S.NO.	ANGLE MEASURED

PRECAUTIONS:

1. The sine bar should not be used for angle greater than 60° because any possible error construction is accentuated at this limit.
2. A compound angle should not be formed by mis-aligning of work piece with the sine bar. This can be avoided by attaching the sine bar and work against an angle plate.
3. As far as possible longer sine bar should be used since using longer sine bars reduces many errors.

RESULT:

1. The angle of the given specimen measured with the sine baris
2. The angle of the given specimen measured with the Bevel Protractor

ADVANTAGES:

- The bevel protractor is used to establish and test angles to very close tolerances. It reads to 5 minutes or $1/20^{\circ}$ and can be used completely through 360° .
- For checking a Vblock
- For measuring Acuteangle..

APPLICATIONS:

- The hypotenuse is a constant dimension—(100 mm or 10 inches in the exampleshown).
- The height is obtained from the dimension between the bottom of one roller and the table'ssurface.
- The angle is calculated by using the sine rule. Some engineering and metalworking reference books contain tables showing the dimension required to obtain an angle from 0-90 degrees, incremented by 1 minuteintervals.
- The two rollers must have equal diameter and be truecylinders.
- For cheking inside face of bevel face of groundface.
- Measure angles veryaccurately.
- What is the use of angleplates?

VIVA - QUESTIONS:

- Name some angle measuringdevices?
- What is the least count of mechanical BevelProtractor?
- What is the least count of optical BevelProtractor?
- What is a sinebar?
- What are the limitations of Sinebar?
- What is the difference between the sine bar and sinecenter?
- What is the use ofV-block?
- How do you specify sinebar?

EXPERIMENT NO. 4**GEAR TOOTH VERNIER CALLIPER****AIM:**

To measure the thickness and height of gear teeth at the pitch line or chordal thickness of teeth and the distance from the top of a tooth the chord using gear tooth caliper.

EQUIPMENT REQUIRED:

1. Gear tooth Vernier caliper
2. Gear of known module
3. Surfaceplate

THEORY:

Tooth thickness is the arc distance measured along the pitch circle from its intercept with one flank to its intercept with the other flank of the tooth.

$$p = \frac{d}{N} = \frac{d}{N} \cdot \frac{1}{d}$$

$$\text{Module, } m = \frac{d}{N} = \left(\frac{1}{dp} \right)$$

Where d = Pitch Circle Diameter (pcd) N = Number of teeth on given gear dp
= Diametral Pitch

Diametral Pitch, $dp = \frac{N}{d} = \frac{N+2}{D}$ Where D = Outside Diameter of Gear

Theoretical Thickness, $W_t = N m \sin(90/N)$

Chordal Height or depth, $h = N m$

$$\% \text{ Error} = \frac{(W_t - W_m)}{W_t} \times 100$$

Addendum is the radial distance from the tip of a tooth to the pitch circle.

In the most of the cases, it is sufficient to measure the chordal thickness i.e. the chord joining the intersection of the tooth profile with the pitch circle because it is difficult to measure length of the arc directly.

Tooth thickness caliper consists of a slide which moves vertically with the help of knob. The jaw moves horizontally with the help of knob there by varying the gap between them. An adjustable tongue, each of which is adjusted independently by adjusting screw on graduated bars, measures the thickness of a tooth at pitch line and the addendum.

PROCEDURE:

1. The given gear caliper is held over the gear and the slide is moved down so that it touches the top of the gartooth.
2. The jaws are made to have contact with the tooth on either side by adjusting the knob.
3. The reading on vertical scale i.e. height is noteddown.
4. The reading on horizontal scale i.e. tooth thickness is noteddown.
5. The above procedure is repeated for five times and readings arenoted.

Least count of given caliper:

TOOTH THICKNESS

S.No.	M.S.R	V.S.R	TOTAL = MSR +(VSR x L.C.)

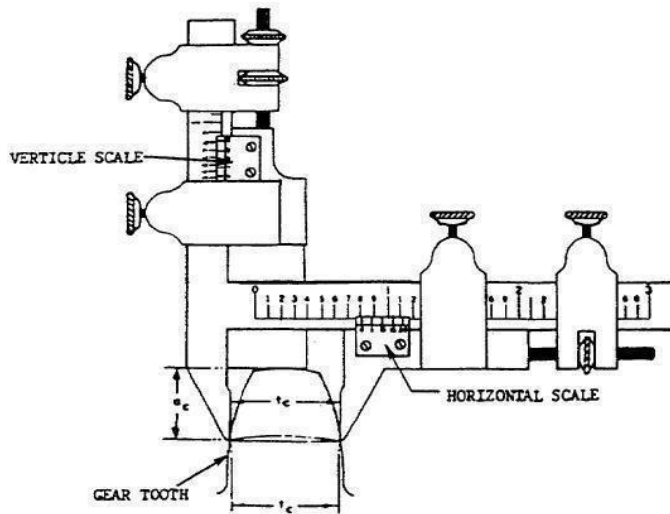

HEIGHT:

S.No.	M.S.R	V.S.R	TOTAL = MSR +(VSR X L.C)

RESULT:

The Height of the given specimen = _

The tooth thickness of the given specimen =

ADVANTAGES:

- _ The method is simple and inexpensive.
- _ However it needs different setting for a variation in number of teeth for a given pitch.
- _ Accuracy is limited by the least count of instrument.
- _ The wear during use is concentrated on the two jaws.
- _ The caliper has to be calibrated at regular intervals to maintain the accuracy measurement.

APPLICATIONS:

- Can be used for measuring hobs, form and thread tools
- Adjusted independently by screws on the graduated bars
- Thickness of a tooth at the pitch line is measured by an adjustable jaw after the addendum is set by the adjustable tongue

VIVA QUESTIONS:

- What are the applications of Gear tooth vernier caliper?
- How do we check the profile of a Gear tooth?
- Define various elements of a gear?
- What is Chordal addendum?
- What is chordal thickness of gear tooth?
- What are the various parts of gear tooth Vernier? v) Differentiate gear tooth Vernier from ordinary Vernier?
- What are the different types of gears?
- What are the various tests conducted on gears?
- What is the other parameter to be measured in gear by using other testing equipment?
- What is rolling gear test?
- What are the various quantitative tests on gears?
- What is the use of gear tooth vernier caliper?
- Explain why chordal width of spur gear is an important dimension to measure?

EXPERIMENT NO - 5**TOOL MAKER'S MICROSCOPE**

AIM: To measure the pitch & angle of the screw thread.

APPARATUS: Tool makers microscope, screw thread specimen

THEORY:

Tool makers microscope is based on the Principle of optics. The microscope consists of a heavy-duty hollow base, which accommodates the illuminating unit underneath, and above this on the top surface of the base, the work table carriage is supported on ball and controlled by micrometer screws. Projecting up from the rear of the base is a column, which carries the microscope unit and various interchangeable eyepieces. The chief applications of the tool room microscope are as follows

1. The determination of relative position of various points on work.
2. Measurement of angle by using a protractor eyepiece.
3. Comparison of thread forms with master profiles engraved in the eyepiece, measurement of pitch and effective diameter.

SPECIFICATION:

MAGNIFICATION	: 30X (Standard)
OBJECTIVE	: 2X
EYEPIECE	: W.F. 15X with cross rectile
FIELD OF VIEW	: 8mm. (approx)
WORKING DISTANCE	: 80mm
OBSERVATION TUBE	: monocular inclined at 30 degree
STAND	: large and heavy base provide extra overall rigidity to the instrument

MEASUREMENT STAGE : 150X150.

Size travel up to 50mm in each direction, least count 6 minutes.

CONSTRUCTION OF MICROSCOPE**BASE:**

The study base rest on three support two of which are adjustable for leveling the instrument. The base has built in all electrical transformers and their control panel and transmitted illuminator with green filter.

ARM:

The arm has a groove guide on which the microscope tube is vertically adjusted by rack and pinion system.

FOCUSSING MECHANISM:

The coarse focusing movement provided in the microscope tube separately. The coarse motion is knurled knob on both side of the tube and has a total travel of 200mm. It also lock any position by lever, this movement is characterized by its exceptionally smooth and accurate precision. The vertical travel or measurement up to 10mm, thickness can be read by the depth dial gauge. The thickness is being measured with the difference of two different focusing of object. The least count of gauge is 0.01.

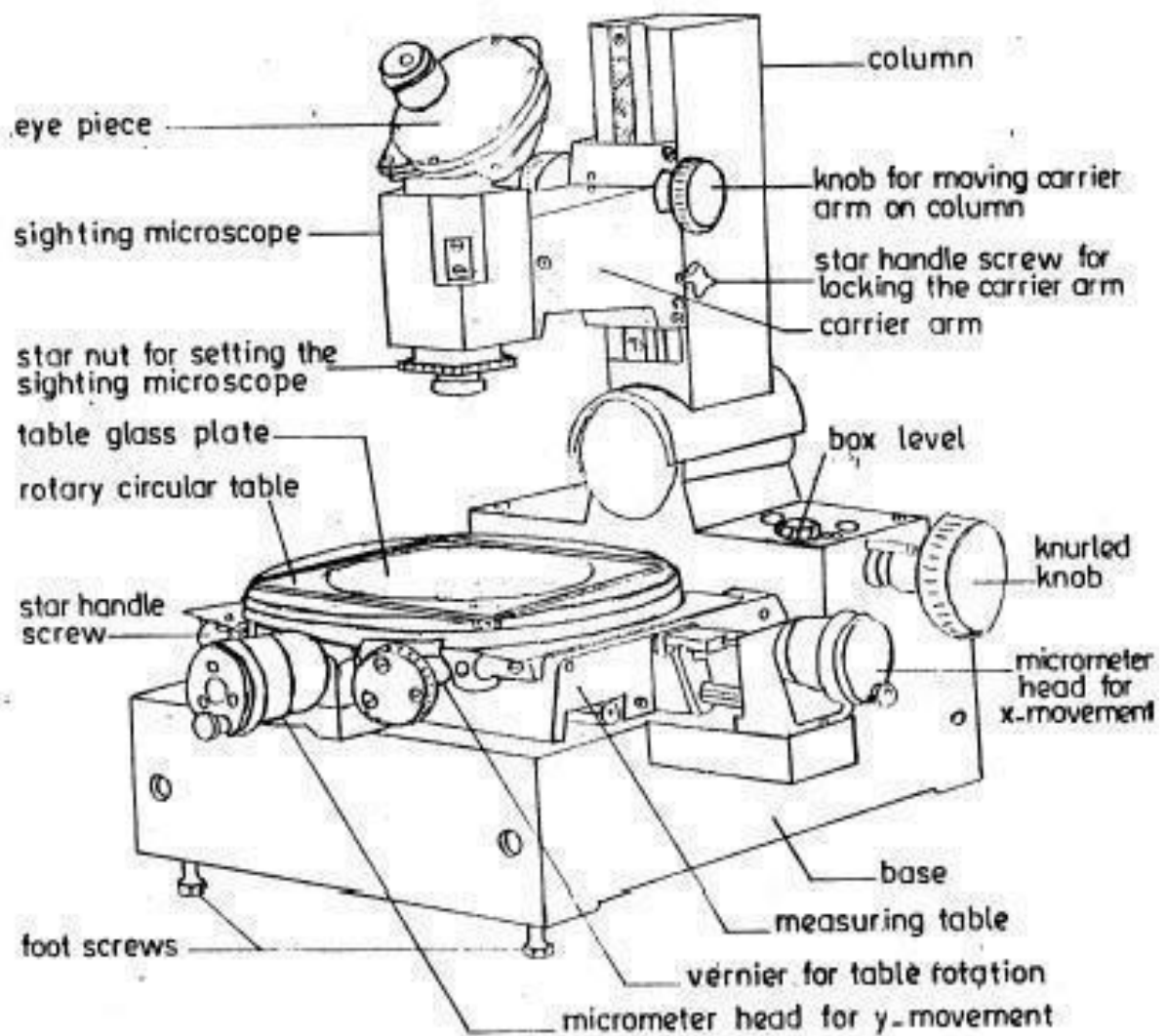

Fig. 1 Tool Makers Microscope

EYEPIECE PROTRACTOR

This unique protractor head graduated 0 to 360 degree with adjustable vernier reading to 6 minutes cross line incorporated in the protractor head rotating in the optical axis of the microscope the cross line graticule is replaceable with many other measuring graticules.

MEASURING STAGE

The stage plate is of 150 X 150 mm having very smooth and precise movements in both axis with special ball racers arrangements. The travel of the stage is 25mm. in both direction with precise imported micrometer head, least count 0.01 or 0.005mm. The stage has two T-slots for mounting accessories like rotary stage, center holding device attachment and V-block etc.

ROTARY STAGE

A rotating stage is fixed in T-slots of square plate having 360 degree graduations on its periphery with vernier reading to 6 minute, and lock screw. All types of horizontal angular measurements can be done with this stage.

ILLUMINATING SYSTEM

Two possible range of illuminating system are provided with standard equipment to meet every application, operated through 6 volts solid state variable light control built in transformer.

1. Sub-stage transmitted light from a bottom source providing collimated green filter halogen light for viewing contours and transparent objects.
2. Surface incident illuminator for shadow free lighting, for high power examination of opaque objects.

PROCEDURE:

MEASUREMENT OF SCREW THREAD PITCH

1. The image of the thread profile is set so that some of the profile coincides with the cross hair as seen on the ground-glass screen.
2. The reading on thimble of the longitudinal micrometer screw is noted down.
3. Then the part is traversed by the micrometer screw until a corresponding point on the profile of the next thread coincides with the crosshairs.
4. The reading on thimble is again noted and the difference in two readings gives the actual pitch of the screw.

MEASUREMENT OF ANGLE OF THREAD

1. It is determined by rotating the screen until a line on the screen coincides with one flank of the thread profile
2. The angle of screen rotation is noted and then the screen is further rotated till the same line coincides with the other flank of thread. The difference in two angular readings gives the actual angle of thread on the screw.

PITCH OF THE THREAD

S. No.	Initial micrometer readings on thread pitch A(mm)	Final micrometer readings on thread pitch B(mm)	Pitch of the thread B-A (mm)

FLANK ANGLE OF THE THREAD:

S. No.	Initial flank angle A (Deg)	Final flank angle B (Deg)	Flank angle = B-A (Deg)

PRECAUTIONS:

1. The coincidence on the component & cross hairs must be carefully matched.
2. Eyepieces are to be handled carefully.
3. Don't expose eyes directly to the light source.

RESULT:

The pitch and flank angle of the given object is measured with toolmakers microscope are tabulated.

ADVANTAGES:

- As compared to the optical comparators, a tool maker's microscope is preferred when the z-axis height information is required.
- The stage can be equipped with linear scales.
- They can easily adapt to both camera CCTV's for photo documentation requirements.
- The toolmaker's microscope offers a variety of optical techniques. Moreover, it can use optics, which offer higher magnification resolution for better measuring accuracy.
- It is ideal for measurements of hardness test indentations.

APPLICATIONS: **Determining relative positions**

Here, the microscope is used to determine the relative positions of different points by simply measuring the travel that is necessary for bringing a second point to the position that was formerly occupied by the first and so forth.

 Measuring angles

Using this microscope, it is possible to measure the angles by using the protractor eyepiece. This allows for the angles of the object to be viewed and determined. This is where the microscope is used to do comparison of the thread forms, measuring of the pitch and diameter. Here, the microscope achieves this using the master profiles engravings in the eyepiece.

 Comparing with a scale

This is where the images of the object are compared with the scale in the projection screen.

VIVA-QUESTIONS:

- What are the applications of Toolmaker's microscope?
- State the principle involved in Toolmaker's microscope?
- How to change the magnification in Toolmaker's microscope?

EXPERIMENT NO. 6**SURFACE ROUGHNESS MEASUREMENT****AIM:**

To measure the surface roughness of a given specimen

APPARATUS: SURF TEST301

Introduction:

Surface Roughness is like a fingerprint left behind by the manufacturing process.

1. The surface irregularities of small wavelength are called primary texture or roughness these are caused by direct action of the cutting elements on the material i.e., cutting tool shape, feed rate or by some other disturbances such as friction, wear or corrosion.
2. The surface considerable wavelength of a periodic character are called secondary texture or waviness. These irregularities result due to inaccuracies of slides, wear of guides, misalignment of centers, non-linear feed motion, vibrations of any kind etc.

Elements of Surface Texture

Actual Surface: It refers to the surface of a part which is actually obtained after manufacturing process.

Nominal surface: A nominal surface is theoretical, geometrically perfect surface which does not exist in practice, but it is an average of the irregularities that are superimposed on it.

Profile: It is defined as the contour of any section through a surface.

Lay: It is the direction of predominant surface pattern produced by the tool marks or scratches, generally surface roughness is measured perpendicular to the lay. **Sampling Length:** It is the length of the profile necessary for the evaluation of the irregularities to be taken into account

Roughness Height: This is rated as the arithmetical average deviation expressed in micrometers normal to an imaginary center line, running through the profile **Roughness Width:** Roughness width is the distance parallel to the normal surface between successive peaks or ridges that constitute the predominant pattern of the roughness.

Measuring instruments:



1. Profilograph

This is an optical instrument and is used for direct measure of the surface quality. The principle of operation is shown in fig.1 A finely pointed stylus mounted in the pickup unit, is traversed across the surface either by hand or motor drive. The work to be tested is placed on the table of the instrument. It is traversed by means of a lead screw. The stylus, which is pivoted to a mirror, moves over a tested surface. A light source sends a beam of light through lens and a precision slit to the oscillating mirror. The reflected beam of light is directed to a revolving drum, upon which a sensitized film is arranged. The drum is rotated through 2-bevel gears from the same lead screw. A profilograph will be obtained from the sensitized film, that may be subsequently analyzed to determine the value of the surface roughness.

2. Tomlinson surfacemeter

This is purely a mechanical lever operated piece of equipment. The diamond stylus on

the recorder is held by spring pressure against the surface of a lapped steel cylinder. The stylus attached to the body of the instrument by means of a leaf spring and it has some height adjustment. The lapped cylinder is supported on one side by the stylus and on the other by two fixed rollers as shown in fig.2

The stylus is restrained from all motions except the vertical one by the tension in the coil and leaf spring. The tensile forces in these two springs also keep the lapped cylinder in horizontal position. A light arm is attached to the lapped steel cylinder, and it carries at its tip a diamond scribe which leans against a smoked glass.

While traversing across the surface of the job, any vertical movement of the stylus caused by the surface irregularities causes the lapped cylinder to roll. Thus, vertical movement coupled with horizontal movement produces a track on the glass magnified in vertical direction and there being no horizontal magnification.

3. Taylor-Hobson-Talysurf

Taylor-Hobson-Talysurf is a stylus and skid type of instrument working on carrier modulating principle. Its response is more rapid and accurate as compared to Tomlinson Surface Meter. The measuring head of this instrument consists of sharply pointed diamond stylus of about 0.002mm tip radius and skid or shoe which is drawn across the surface by means of a motorized driving unit.

In this instrument the stylus is made to trace the profile of the surface irregularities, and the oscillatory movement of the stylus is converted into changes in electric current by the arrangement as shown in fig.3. The arm carrying the stylus forms an armature which pivots about the centre piece of E-shaped stamping. On two legs of (outer pole pieces) the E-shaped stamping there are coils carrying an a.c current. These two coils with other two resistances form an oscillator. As the armature is pivoted about the central leg, any movement of the stylus causes the air gap to vary and thus the amplitude of the original a.c current flowing in the coils is modulated. The output of the bridge thus consists of modulation only as shown in fig.3 this is further demodulated so that the current now is directly proportional to the vertical displacement of the stylus. The demodulated output is caused to operate a pen recorder to produce permanent record and the meter to give numerical assessment directly.

DESCRIPTION OF SURFTEST SJ-301

The SurfTest SJ-301 is a stylus type surface roughness measuring instrument developed for shop floor use. The SJ-301 is capable of evaluating surface texture with variety of parameters according to various national standards and international standard. The measurement results are displayed digitally/graphically on the touch panel, and output to the built-in printer.

The stylus of the SJ-301 detector unit traces the minute irregularities of the work piece

surface. Surface roughness is determined from the vertical stylus displacement produced during traversing over the surface irregularities. The measurement results are displayed digitally/graphically on the touch panel.

OBSERVATIONS:

Specimen. No.	R _a Microns	R _q Microns	R _z Microns	R _t Microns	R _{sk}	R _{ku}
1.						
2.						
3.						

Result: The various roughness parameters for different specimens are tabulated.

ADVANTAGES:

- The main advantage of such instruments is that the electrical signal available can be processed to obtain any desired roughness parameter or can be recorded for display or subsequent analysis.
- Therefore, the stylus type instruments are widely used for surface texture measurements in spite of the following disadvantages.

DISADVANTAGES:

- These instruments are bulky and complex.
- They are relatively fragile.
- Initial cost is high.
- Measurements are limited to a section of a surface. (v) Needs skilled operators for measurements.
- Distance between stylus and skid and the shape of the skid introduce errors in measurement for wavy surfaces.

APPLICATIONS:

- Low-coherence profilometers deliver fast, reliable, and non-contact 3D surface measurements – with precision better than 1 μm. Surfaces are rapidly characterized in terms of shape, roughness, flatness, waviness, and other surface qualities
- High-speed scanning: 1,000 to 30,000 points/sec and higher
- Real-time feedback on manufacturing or coating processes: application data is typically forwarded to process control software
- Easy visual inspection: depth profiles, 2D cross-sections (B-scans or C-scans) and 3D surface maps.

VIVA –QUESTIONS:

- Define the following terms a) Roughness b) Waviness c) Lay d) Sampling Length
- Explain the terms R_a , R_z , RMS.
- What are the various methods of measuring surface roughness?
- Explain the use of dial bore gauge?
- What is the principle involved in spirit levels? What is
- primary texture?
- What is secondary texture? What is Lay?
- What do you mean by traversing length and sampling length?
- Define R_a , R_q and R_y vi) What is calibration ? and why is it necessary for roughness measurement.

PART- B MACHINE TOOLS**EXP : 2 STEP TURNING AND TAPER TURNING ON LATHE**

AIM: To perform Step turning and Taper turning operations on the given work piece

MATERIAL REQUIRED: Mild steel rod of 25 mm diameter and 100 mm long.

TOOLS REQUIRED: Vernier calipers, steel rule, spanner, chuck spanner, and H.S.S. single point cutting tool.

SPECIFICATION OF LATHE:

Length of bed	1390 mm
Width of bed	200 mm
Height of centers	165 mm
Admit between centers	700 mm
Lead screw pitch	4TPI
Power of the motor	1 h.p.

THEORY:

Lathe removes undesired material from a rotating work piece in the form of chips with the help of a tool which is traversed across the work and can be fed deep in work. The tool material should be harder than the work piece and the later help securely and rigidly on the machine. The tool may be given linear motion in any direction. A lathe is used principally to produce cylindrical surfaces and plane surfaces, at right angles to the axis of rotation. It can also produce tapers and bellows etc.

OPERATION CHART:

S NO.	SEQUENCE OF OPERATIONS	CUTTING TOOL USED
1.	Facing	H.S.S Single Point tool
2.	Rough turning	H.S.S Single Point tool
3	Finish turning	H.S.S Single Point tool
4	Step turning	Parting tool
5	Taper turning	H.S.S Single Point tool
6	Knurling	Knurling tool
7	Chamfering	H.S.S Single Point tool

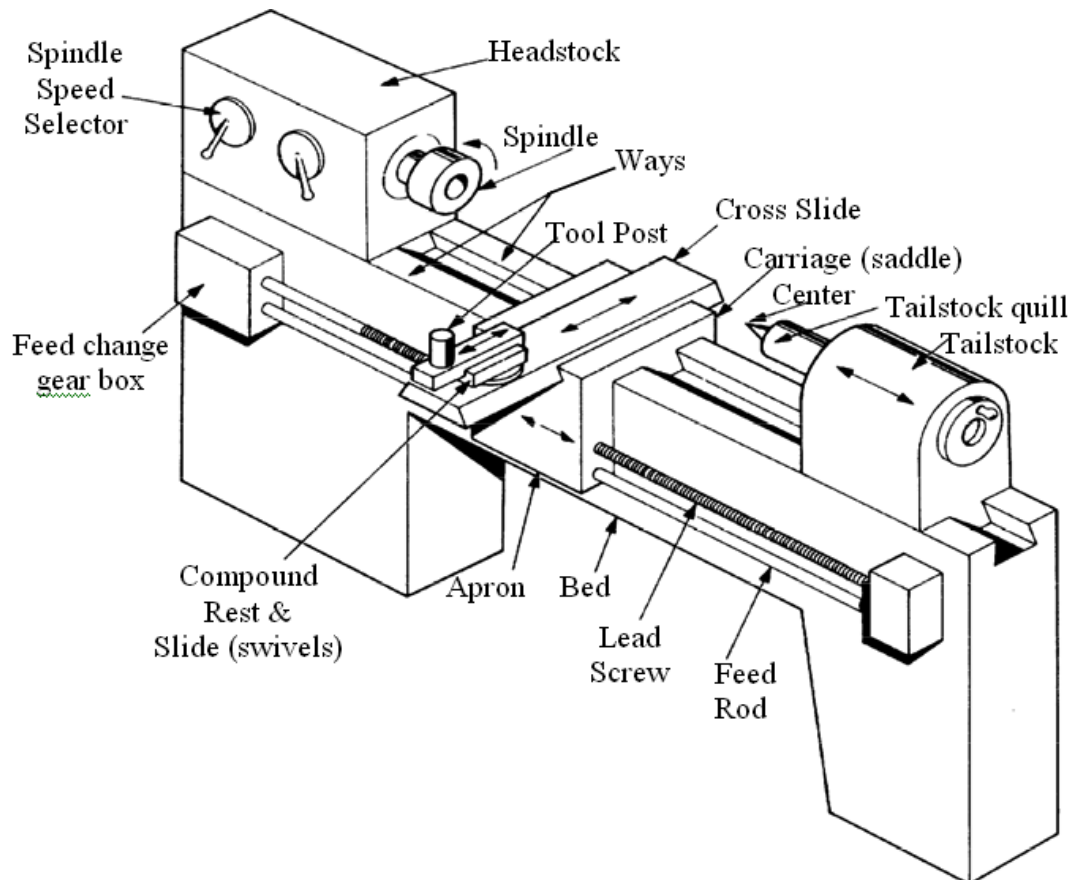

PROCEDURE:

1. The work piece and HSS single point cutting tool are securely held in the chuck and tool post respectively.
2. Operations such as facing, rough turning and finish turning are performed on a given mild steel bar one after the other in sequence up to the dimensions shown. Then the step turning is performed using parting tool.
3. Then the compound rest is swiveled by calculated half taper angle and taper is generated on the work piece. Rotation of the compound slide screw will cause the tool to be fed at the half-taper angle.
4. HSS single point cutting tool is replaced by the knurling tool and knurling operation is performed at the slowest speed of the spindle.
5. The knurling tool is replaced by the HSS single point tool again; the work piece is removed from the chuck and re fixed with the unfinished part outside the chuck. This part is also rough turned, finish turned and facing is done for correct length.
6. Finally, the chamfering is done at the end of the work piece.

OBSERVATIONS: (a) Record the following in a tabular form:

Machine Tool Specifications (Table A)

Machine	Type & Make	Size	Speed given to		Feed given to		Type of Surface Produced
			Tool	Work	Tool	Work	
lathe							

Speed and Feed Data (Table B)

No.	Lathe	
	Speed	Feed
1.		
2.		
3.		
4.		
5.		
6.		

PRECAUTIONS:

1. Operate the machine at optimal speeds
2. Do not take depth of cut more than 2 mm.
3. Knurling should be done at slow speeds and apply lubricating oil while knurling
4. Care should be taken to obtain the required accuracy.

RESULT:

APPLICATIONS:

Applications	Description
Woodturning	Used to make wooden objects such as ornate table legs, baseball bats, wooden bowl, and platters; operators use a variety of tools to form
Metalworking	Used to create precision parts; most often associated with a multistep process requiring different tools for each step
Metal Spinning	A process where metal spins on a spindle, while the operator works it with tools; an automated process
Acrylic Spinning	Involves spinning acrylic on a spindle to form items from acrylic; most often used in the making of the top pieces for trophies
Thermal Spraying	Combines the rotating spindle with the painting process; the paint sticks to the stock via processes involving heating the paint materials

ADVANTAGES:

One advantage of a lathe machine is that it can perform very detailed and intricate designs.

DIS-ADVANTAGES:

One disadvantage of a lathe machine is that these machines are more expensive than other types of machines used to produce this type of work.

EXP.3 THREAD CUTTING AND KNURLING ON LATHE

AIM: To perform V-thread cutting on a lathe forming right hand and left hand metric threads.

MATERIAL REQUIRED

Mild steel bar of 24 mm diameter and 100 mm length

TOOLS AND EQUIPMENT

H.S.S. single point cutting tool, Grooving tool, Threading tool thread gauge, Outside caliper, Chuck key, Tool post key, Steel rule.

OPERATION CHART

S no.	Sequence of Operations	Cutting tool used
1.	Facing	H.S.S Single Point cutting tool
2.	Rough turning	H.S.S Single Point cutting tool
3	Finish turning	H.S.S Single Point cutting tool
4	Step turning	H.S.S Single Point cutting tool
5	Grooving	Grooving tool
6	Thread cutting	Threading tool
7	Chamfering	H.S.S Single Point cutting tool

PRINCIPLE OF THREAD CUTTING

The principle of thread cutting is to produce a helical groove on a cylindrical or conical surface by feeding the tool longitudinally when the job is revolved between centers or by a chuck. The longitudinal feed should be equal to the pitch of the thread to be cut per revolution of the work piece. The lead screw of the lathe, through which the saddle receives its traversing motion, has a definite pitch. A definite ratio between the longitudinal feed and rotation of the head stock spindle should therefore be found out so that the relative speeds of rotation of the work and the lead screw will result in the cutting of a screw of the desired pitch. This is affected by change gears arranged between the spindle and the lead screw or by the change gear mechanism or feed box used in a modern lathe.

Calculation of change-wheels, metric thread on English lead screw:

To calculate the wheels required for cutting a screw of certain pitch, it is necessary to know how the ratio is obtained and exactly where the driving and driven wheels are to be placed. Suppose the pitch

of a lead screw is 12 mm and it is required to cut a screw of 3 mm pitch, then the lathe spindle must rotate 4 times the speed of the lead screw that is

$$\frac{\text{Spindle turn}}{\text{Lead screw turn}} = \text{Means that we must have}$$

$$\frac{\text{Driver teeth}}{\text{Driven teeth}} = \text{Since a small gear rotates faster than a larger one with which it is connected.}$$

Hence we may say,

$$\frac{\text{Driver teeth}}{\text{Driven teeth}} = \frac{\text{lead screw turn pitch of the screw to be cut}}{\text{spindle turn pitch of the lead screw}}$$

In BRITISH SYSTEM

$$\frac{\text{Driver teeth}}{\text{Driven teeth}} = \frac{\text{Threads per inch on lead screw}}{\text{Threads per inch on work}}$$

Often engine lathes are equipped with a set of gears ranging from 20 to 120 teeth in steps of 5 teeth and one translating gear of 127 teeth. The cutting of metric threads on a lathe with an English pitch lead screw may be carried out by a translating gear of 127 teeth.

$$\frac{\text{Driver teeth}}{\text{Driven teeth}} = \frac{5 p n}{127}$$

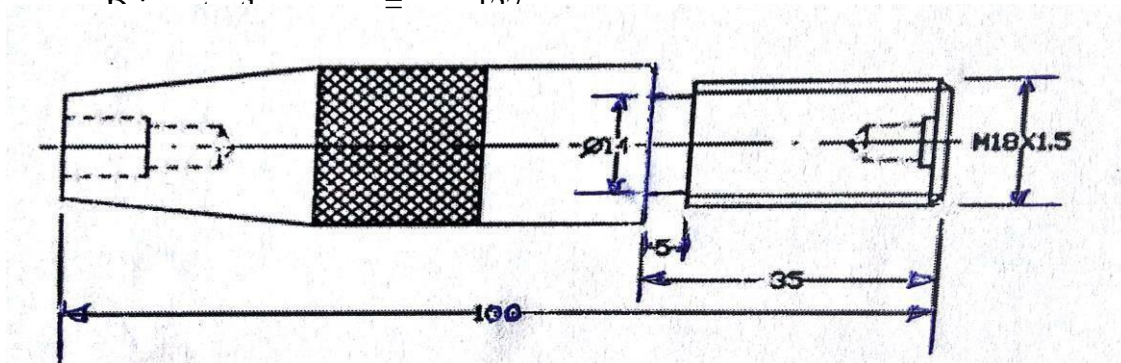

This is derived as follows:

$$\frac{\text{Driver teeth}}{\text{Driven teeth}} = \frac{\text{pitch of the work}}{\text{pitch of the lead screw}} = \frac{p}{(1/n) \times (127/5)} = \frac{pn}{127}$$

$$\text{Since, pitch} = \frac{1}{\text{No. of threads per inch}}$$

THREAD CUTTING OPERATION:

In a thread cutting operation, the first step is to remove the excess material from the work piece to make its diameter equal to the major diameter of the screw thread. Change gears of correct size are

then fitted to the end of the bed between the spindle and the lead screw. The shape or form of the thread depends on the shape of the cutting tool to be used. In a metric thread, the included angle of the cutting edge should be ground exactly 60° . The top of the tool nose should be set at the same height as

the center of the work piece. A thread tool gauge is usually used against the turned surface to check the cutting tool, so that each face of the tool may be equally inclined to the center line of the work piece as shown.

The speed of the spindle is reduced by one half to one – fourth of the speed require for turning according to the type of the material being machined and the half – nut is then engaged. The depth of cut usually varies from 0.05 to 0.2 mm is given by advancing the tool perpendicular to the axis of the work.

After the tool has produced a helical groove up to the desired length of the work, the tool is quickly withdrawn by the use of the cross slide, the half-nut disengaged and the tool is brought back to the starting position to give a fresh cut. Before re-engaging the half-nut it is necessary to ensure that the tool will follow the same path it has traversed in the previous cut, otherwise the job will be spoiled. Several cuts are necessary before the full depth of thread is reached arising from this comes the necessity to “pick-up” the thread which is accomplished by using a chasing dial or thread indicator.

Chasing dial or thread indicator

The chasing dial is a special attachment used in modern lathes for accurate “picking up” of the thread. This dial indicates when to close the split of half nuts. This is mounted on the right end of the apron. It consists of a vertical shaft with a worm gear engaged with the lead screw. The top of the spindle has a revolving dial marked with lines and numbers. The dial turns with the lead screw so long the half nut is not engaged.

If the half-nut is closed and the carriage moves along the dial stands still. As the dial turns, the graduations pass a fixed reference line. The half-nut is closed for all even threads when any line on the dial coincides with the reference line. For all odd threads, the half-nut is closed at any numbered line on the dial determined from the charts. If the pitch of the thread to be cut is an exact multiple of the pitch of the lead screw, the thread is called even thread, if otherwise the thread is odd thread.

In a chasing dial, the rule for determining the dial division is: In case of metric threads, the product of the pitch of lead screw and the no. of teeth on the worm wheel must be an exact multiple of the pitch of the threads to be cut. In case of English threads, the product of the threads per inch to be cut and the number of teeth on the worm wheel must be an exact multiple of the number of threads per inch of the lead screw. For example, if the pitch of the lead screw is 6 mm and the worm wheel has 15 teeth.

The product will be 90. so any pitch which is exactly divisible by 90, such as 1, 1.25, 2.25, 3, 3.75, 4.5, 5, 6, 7.5, 9, 10, 15, 30, 45, 90 may be picked up when any line of the dial coincides with the reference line.

Right hand and left-hand thread:

If the bolt advances into the nut when rotated in clockwise direction, the thread is called right-hand thread. When cutting a right-hand thread the carriage must move towards the head stock.

If the bolt advances into the nut when rotated in counter-clockwise direction, the thread is called left-hand, for a left hand thread the carriage moves away from the head stock and towards the tail stock. The job moves as always in the anti-clock wise direction when viewed from the tail stock end. The direction at which the carriage moves in relation to lathe head stock is controlled by means of the tumbler gears or bevel gear feed reversing mechanism.

PROCEDURE:

The work piece and HSS single point cutting tool are fixed in chuck and tool post respectively.

1. Operations such as facing, rough turning finish turning and step turning are performed on the given mild steel bar one after the other in sequence up to the dimensions shown.

2. Single point cutting tool is replaced by a grooving tool and grooving operation is performed at half of the normal spindle speed.

3. The grooving tool is replaced by a threading tool. Right hand and left hand metric threads are cut on the work piece up to the required length at $1/4^{\text{th}}$ of the normal speed of the spindle.

4. Threading tool replaced by a single point cutting tool again and finally chamfering is done at right end of the work piece at normal spindle speed.

PRECAUTIONS:

1. Low spindle speeds should be used for accurate threads in thread cutting operation.
2. Ensure correct engage and dis-engage of half-nut.

Plenty of oil should be flowed on the work and tool during thread cutting

OBSERVATIONS: Record the following in a tabular form:

Machine Tool Specifications (Table A)

Machine	Type & Make	Size	Speed given to		Feed given to		Type of Surface Produced
			Tool	Work	Tool	Work	
lathe							

Speed and Feed Data (Table B)

No.	Lathe	
	Speed	Feed
1.		
2.		
3.		
4.		
5.		
6.		
7.		
8.		

RESULT:

ADVANTAGES:

One advantage of a lathe machine is that it can perform very detailed and intricate designs

DISADVANTAGES:

One disadvantage of a lathe machine is that these machines are more expensive than other types of machines used to produce this type of work.

VIVA QUESTIONS:

1. What is a lathe?
2. What are the various operations can be performed on a lathe?
3. What are principle parts of the lathe?
4. What are the types of headstock?
5. State the various parts mounted on the carriage?
6. What are the four types of tool post?
7. What is an apron?

8. State any two specification of lathe?

9. List any four types of lathe?

EXP 4 MANUFACTURING OF SPUR GEAR USING MILLING MACHINE

AIM: To perform spur gear cutting on milling machine on the given specimen (mild steel) & get to its correct dimensions.

MATERIALS REQUIRED: mild steel work piece.

MACHINE REQUIRED: milling machine

MEASURING INSTRUMENTS: Vernier calipers

CUTTING TOOLS: Plane (face) milling cutter.

MARKING TOOLS: steel rule, scriber

- a. Work holding fixtures: work piece supporting fixtures
- b. Miscellaneous tools: Hammer, brush, Allen keys

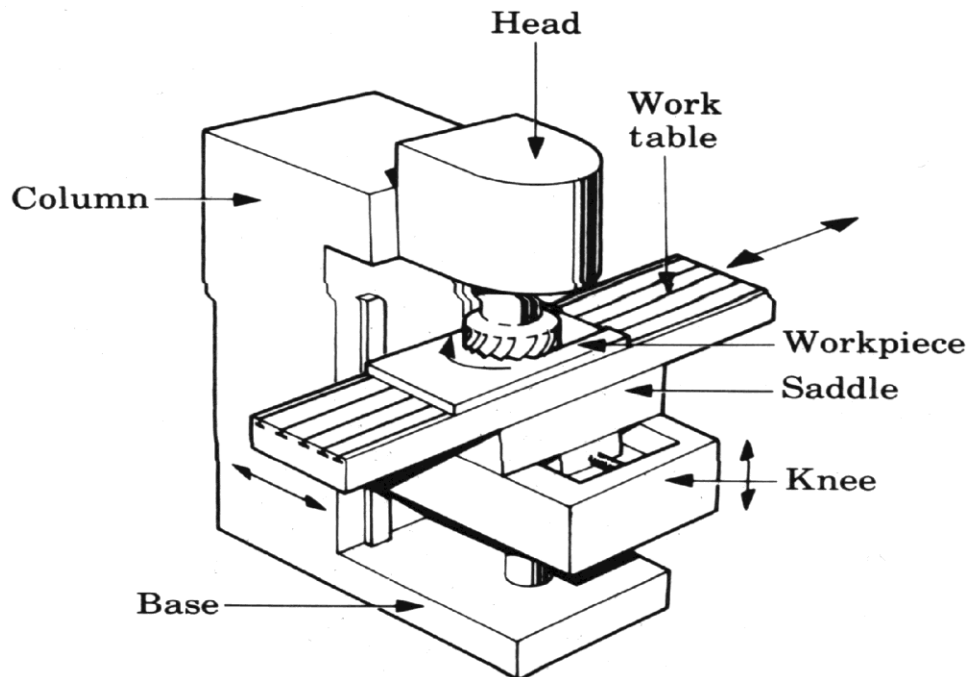
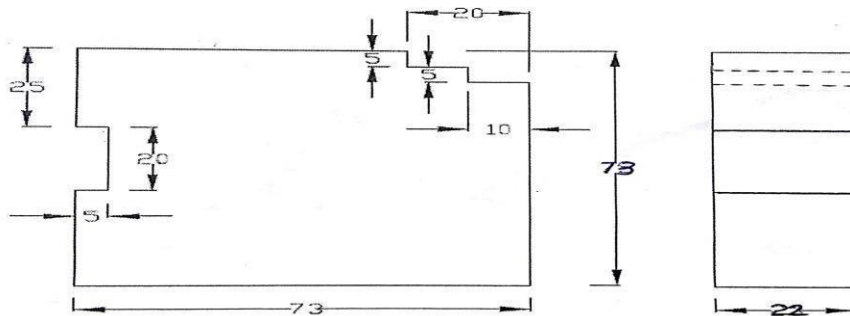

OBSERVATION: Record the following in a tabular form:

Machine Tool Specifications (Table A)

Machine	Type & Make	Size	Speed given to		Feed given to		Type of Surface Produced
			Tool	Work	Tool	Work	
Milling m/c							

Speed and Feed Data (Table B)

No.	Milling m/c.	
	Speed	Feed
1.		
2.		
3.		
4.		
5.		

PROCEDURE:

1. The dimensions of the given rod are checked with the steel rule.
2. The given rod is fixed in the vice provided on the machine table such a, one end of it is projected outside the jaws of the vice.
3. A face milling cutter is mounted on the horizontal milling machine spindle and one end of the rod is face milled, by raising the table so that the end of the rod faces the cutter.
4. The rod is removed from the vice and fitted in the reverse position.
5. The other end of rod is face milled such that, the length of the job is exactly 100 mm.
6. The table is lowered and the rod is removed from the vice and refitted in it such that, the top face of the rod is projected from the vice jaws.
7. The face milling cutter is removed from the spindle and the arbor is mounted in the spindle; followed by fixing the plain milling cutter.
8. The top surface of the job is slab milled; first giving rough cuts followed by a finish cut.
9. The job is removed from the vice and refitted in it such that, the face opposite to the above, comes to the top and projects above the vice jaws.
10. The top surface of the job is milled in stages; giving finish cuts towards the end such that, the height of the job is exactly 40 mm.
11. The burrs if any along the edges are removed with the help of the flat file.

12. Learn the names of the major units and the components of each machine. Record these details (Table A). Please ensure that the main isolator switch is off and check that the machine cannot be inadvertently started. Do not remove guards). Use the manufacture's handbook for details that cannot be inspected.
13. Record the obtainable speed and feed values (Table B).
14. Note down the special features of the speed and feed control on each machine

PRECAUTIONS:

1. The milling machine must be stopped before setting up or removing a work piece, cutter or other accessory.
2. Never stop the feeding of job when the cutting operation is going on, otherwise the tool will cut deeper at the point where feed is stopped.
3. All the chips should be removed from the cutter. A wiping cloth should be placed on the cutter to protect the hands. The cutter should be rotated in the clockwise direction only for right handed tools.
4. The work piece and cutter should be kept as cool as possible (i.e. coolant should be used where necessary to minimize heat absorption).
5. The table surface should be protected with a wiping cloth.
6. Tool must be mounted as close to the machine spindle as possible.

RESULT:**ADVANTAGE:**

1. Both flat and formed surface can be produced.

DISADVANTAGES:

- (i) Quality of surface generated will be slightly wavy
- (ii) Lubrication is difficult.
- (iii) Needs heavy fixture since the cutting force results in lifting the work piece.
- (iv) Results in vibration.
- (v) Cutting force is not uniform.

APPLICATIONS:

Milling machines are widely used in the tool and die making industry and are commonly used in the manufacturing industry for the production of a wide range of components .Typical examples are the milling of flat surface, indexing, gear cutting, as well as the cutting of slots and key-ways.

VIVA QUESTIONS:

1. What are the specifications of the milling machine?
2. Mention the various movements of universal milling machine table?
3. State any two comparisons between plain & universal milling machine?
4. What are the cutter holding devices?
5. List the various type of milling attachment?
6. Write any ten nomenclature of plain milling cutter?
7. What are the advantages of milling process?
8. what are the down milling processes?
9. List out the various milling operations?
10. What does term indexing mean?
11. What are the three types dividing heads?
12. What is cam milling?
13. What are the different types of thread milling?
14. Gear cutting by single point form tool.
15. List the gear generating process?
16. What is a semi-automatic lathe?
17. What is copying lathe?
18. State the various feed mechanisms used for obtaining automatic feed?
19. List any four holding devices?
20. What are the different operations performed on the lathe?

EXP.5 MACHINING FLAT SURFACE USING SHAPER

MACHINE AIM: To perform V and Dovetail machining & U-cut on the given work

piece. **MATERIALS REQUIRED:** Mild steel / Cast iron / Cast Aluminum.

MACHINE REQUIRED: Shaping machine

MEASURING INSTRUMENTS:

- Vernier calipers,
- Vernier height gauge,
- Dial indicator,
- Required steel ball.

CUTTING TOOLS

H.S.S tool bit, V-tool, Plain tool, Grooving tool.

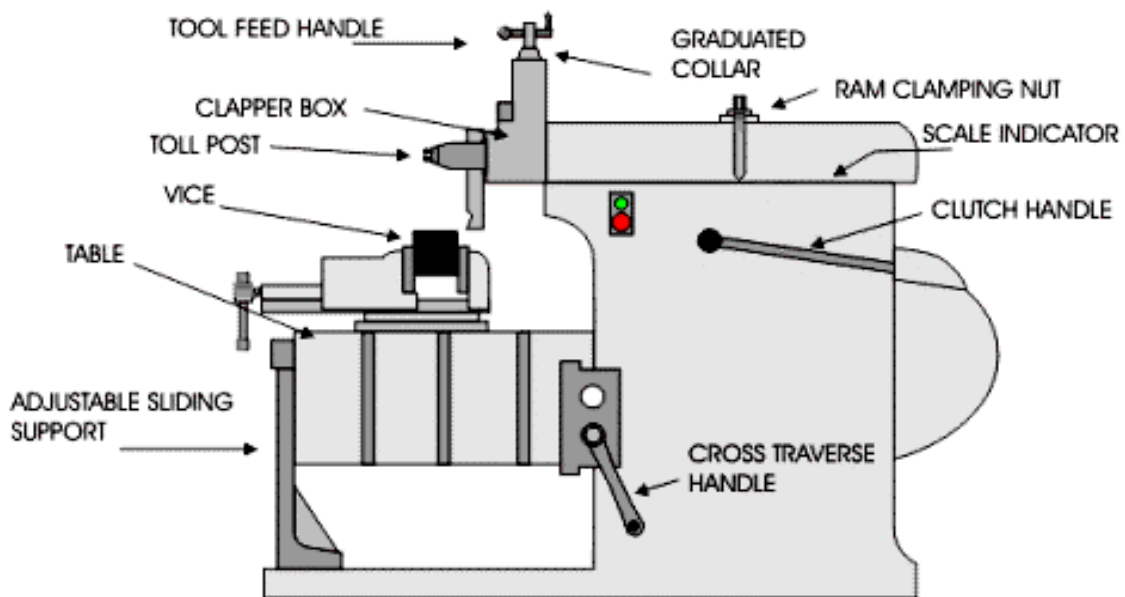

OBSERVATION Record the following in a tabular form:

Machine Tool Specifications (Table A)

Machine	Type & Make	Size	Speed given to		Feed given to		Type of Surface Produced
			Tool	Work	Tool	Work	

Shaper M/c.							
----------------	--	--	--	--	--	--	--

Speed and Feed Data (Table 2)

No.	Shaper M/c.	
	Speed	Feed
1.		
2.		
3.		
4.		
5.		

PROCEDURE:

1. Run the machine at low speed and observe the motions, which control the shapes of the surfaces produced. Note particularly the features, which control the geometrical form of the surface.
2. Learn the names of the major units and the components of each machine. Record these details (Table A). (Please ensure that the main isolator switch is off and check that the machine cannot be inadvertently started. Do not remove guards). Use the manufacture's handbook for details that cannot be inspected.
3. Record the obtainable speed and feed values (Table B).
4. Note down the special features of the speed and feed control on each machine.
5. Measuring of specimen.
6. Fixing of specimen in the machine vice of the shaping machine
7. Giving the correct depth and automatic feed for the slot is to be made.
8. Check the slot with the Vernier calipers & precision measurement by slip gauges at the end.

PRECAUTIONS:

1. The shaping machine must be stopped before setting up or removing the work piece
2. All the chips should be removed from the cutter.

RESULTS:

ADVANTAGES:

1. Single point cutting tools used in shaper are expensive these tools can be easily grounded to any desirable shape.
2. Shaper set-up is very quick and easy and can be readily changed from one job to another.

DIS ADVANTAGES:

1. The shaper is unsuitable for generating the flat surfaces on very large parts because of limitations on the stroke and overhang the ram.
2. The primary motion is accomplished by rack and pinion drive using a variable speed motor.

APPLICATIONS:

A shaper machine is a cutting machine that cuts a linear tool path using a linear relative motion between a single-point cutting tool and the piece of work. This type of machine is usually used to machine flat, straight surfaces, although it is also able to perform more complex tasks including the machining of dovetail slides, gear teeth and internal spline, keyways in the boss of either gears or pulleys and many other forms of work that take advantage of the machines linear relative motion.

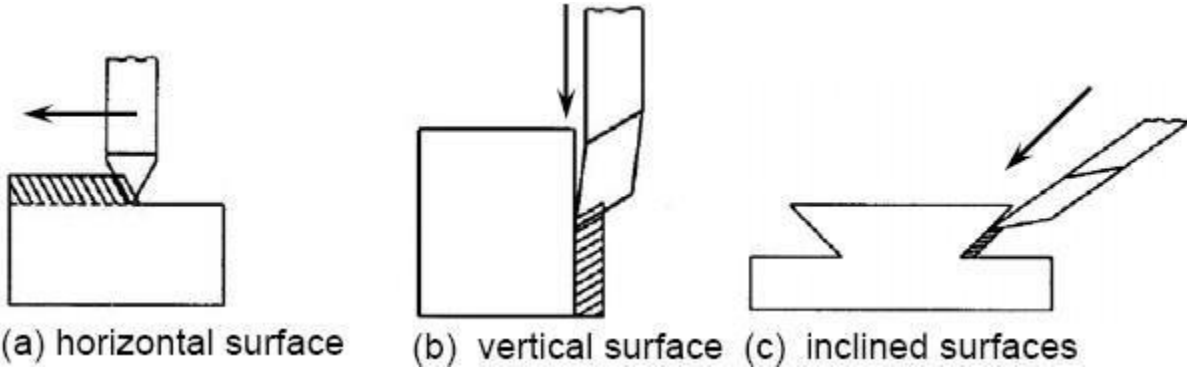
**VIVA QUESTIONS:**

1. Mention the applications of gear shaping process?
2. What are the limitations of gear hobbing?
3. What is shaper?
4. List any four important parts of a Shaper?
5. How the feed & depth of cut is given to the shaper?
6. Mention any four-shaper specification?
7. How the planer differs from the shaper?

EXP 6 DRILLING AND TAPPING

AIM: To drill the given work piece as required and then to perform to make, counter boring, countersinking and tapping operations

MATERIALS REQUIRED: mild steel specimen, coolant (oil and water mixture), lubricant oil, nut and bolt.

MACHINE REQUIRED: Drilling machine

MEASURING INSTRUMENTS: Vernier calipers

CUTTING TOOLS:

Button pattern stock,
Dies,
Drill bits,
Hand taps,
Tap wrench.

MARKING TOOLS: Dot punch

Work holding fixtures:

Bench vice, V-Block

Miscellaneous tools:

Brush, Allen Keys

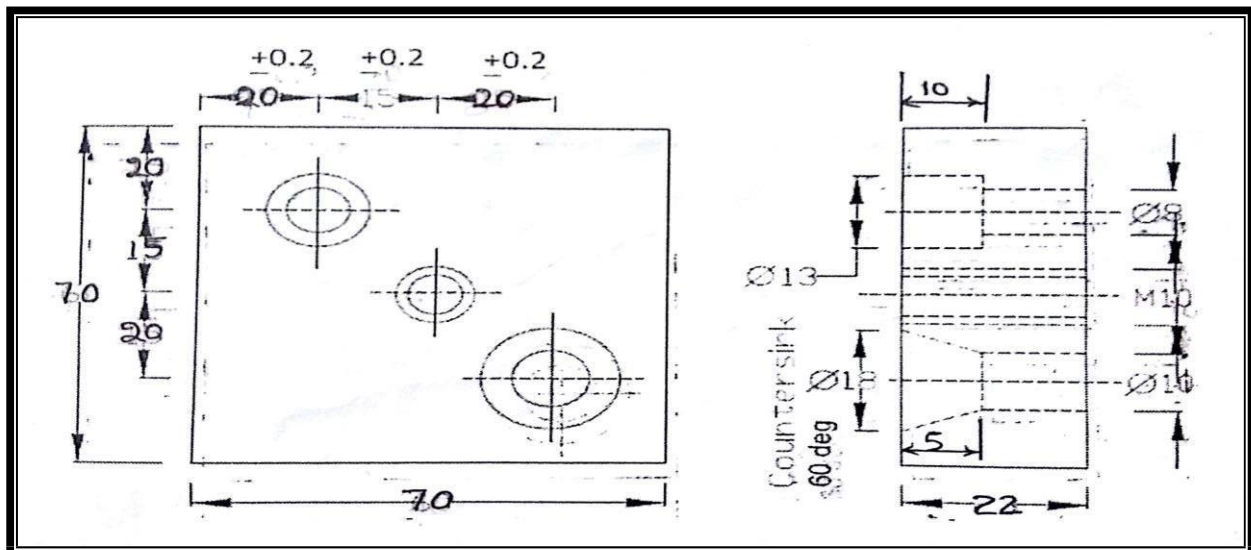
DIAGRAM:

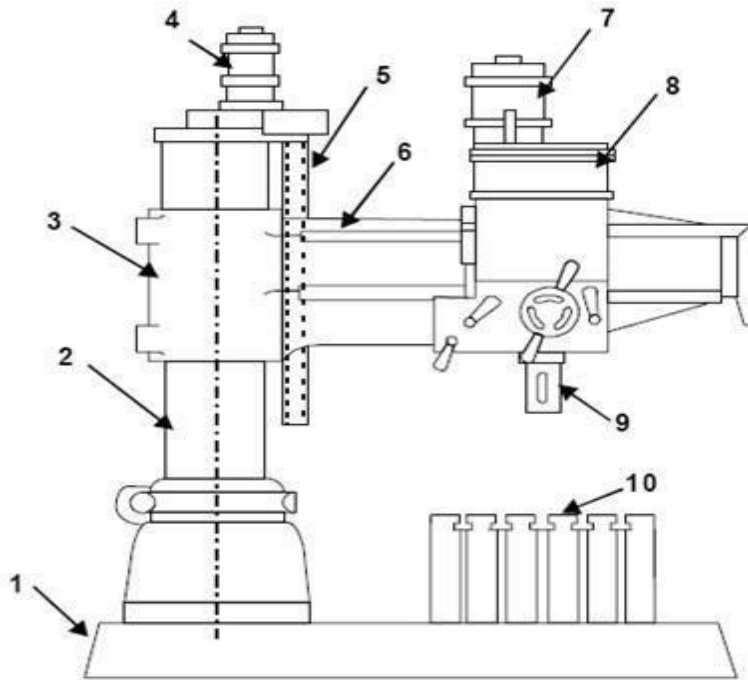

PARTS OF RADIAL DRILL:

- 1. Base
- 2. Column
- 3. Radial arm
- 4. Motor for elevating screw
- 5. elevating screw
- 6. Guide ways
- 7. Motor for driving spindle
- 8. Drill head
- 9. Drill spindle
- 10. Table

OBSERVATION

Record the following in a tabular form:

Machine Tool Specifications (Table A)

Machine	Type & Make	Size	Speed given to		Feed given to		Type of Surface Produced
			Tool	Work	Tool	Work	
Drilling m/c							

Speed and Feed Data (Table B)

No.	Drilling M/c.	
	Speed	Feed
1		
2		
3		
4		

SEQUENCE OF OPERATIONS:

1. Run the machine at low speed and observe the motions, which control the shapes of the surfaces produced.
2. Note particularly the features, which control the geometrical form of the surface.
3. Learn the names of the major units and the components of each machine. Record these details (Table A). (Please ensure that the main isolator switch is off and check that the machine cannot be inadvertently started. Do not remove guards). Use the manufacture's handbook for details that cannot be inspected.
4. Record the obtainable speed and feed values (Table B).
5. Note down the special features of the speed and feed control on each machine,
6. Mark the center of hole and center punching
7. Drill bit

$$D_d = d_h - p$$

Where,

1. D_h - dia. of the hole,
2. d_d - dia. of drill bit,
3. p = pitch

8. Use the suitable drill size for required tapping

D = Dia. of tap

Tap Drill size = $(D - 1.3p) + 0.2$ – for metric threads

9. Chamfering of specimen

10. Use the sequential tapping as tap set 1, 2, and 3

11. Internal tapping of drilled specimen

12. Filing of specimen on which external threading to be done

13. Measuring the diameter of the specimen & choosing of dies according to it

14. Dying operation (external threading) of the specimen.

PRECAUTIONS:

1. Coolant has to be used while drilling
2. Lubricating oil has to be used to get smooth finish while tapping.

RESULT:

ADVANTAGES:

1. The universal movements of the tool head permit the drill tool located at any desired position over the stationary work piece.
2. Possible to work on odd shaped jobs and to drill larger diameter holes.
3. Accurate precision drilling is possible.

DISADVANTAGES:

1. A skilled worker is a must.
2. Only small size holes can be drilled.

APPLICATIONS:

1. Origination and / or enlargement of existing straight through or stepped holes of different diameter and depth in wide range of work materials – this is the general or common use of drilling machines
2. Making rectangular section slots by using slot drills having 3 or four flutes and 1800 cone angle
3. Boring, after drilling, for accuracy and finish or prior to reaming
4. Counter boring, countersinking, chamfering or combination using suitable tools.

VIVA QUESTIONS:

1. What is meant by drilling?
2. What is gang -drilling machine
3. Mention any four specification of drilling machine?
4. List any four machining operations that can be performed on a drilling machine?
4. What are the different ways to mount the drilling tool?

EXP. 7 PRECISION SURFACE GRINDING

AIM: To perform surface grinding operation on the given (50*50*20) work piece.

MATERIALS REQUIRED: mild steel specimen.

MACHINE REQUIRED: surface grinding machine

MEASURING INSTRUMENTS:

Vernier calipers,

Micrometer.

CUTTING TOOLS: Diamond point dressing block

WORK HOLDING FIXTURES: Magnetic chuck

Experimental Diagram Surface Grinding:

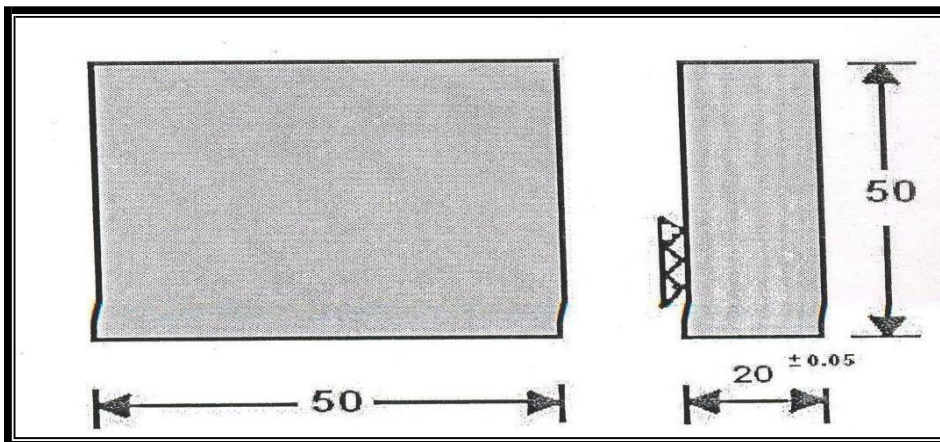

All Dimensions are In mm

MISCELLANEOUS TOOLS:

Wire brush (for cleaning the formed chips),

Lubricant (coolant),

PROCEDURE:

1. Work piece is mounted on magnetic table, so that the line along face of grinding wheel coincides with the edge of work piece.
2. Depth of cut is given to work piece by down feed hand wheel.
3. The work piece is reciprocates under wheel and the table feeds axially between passes to

produce flat surface and to get required size of work piece.

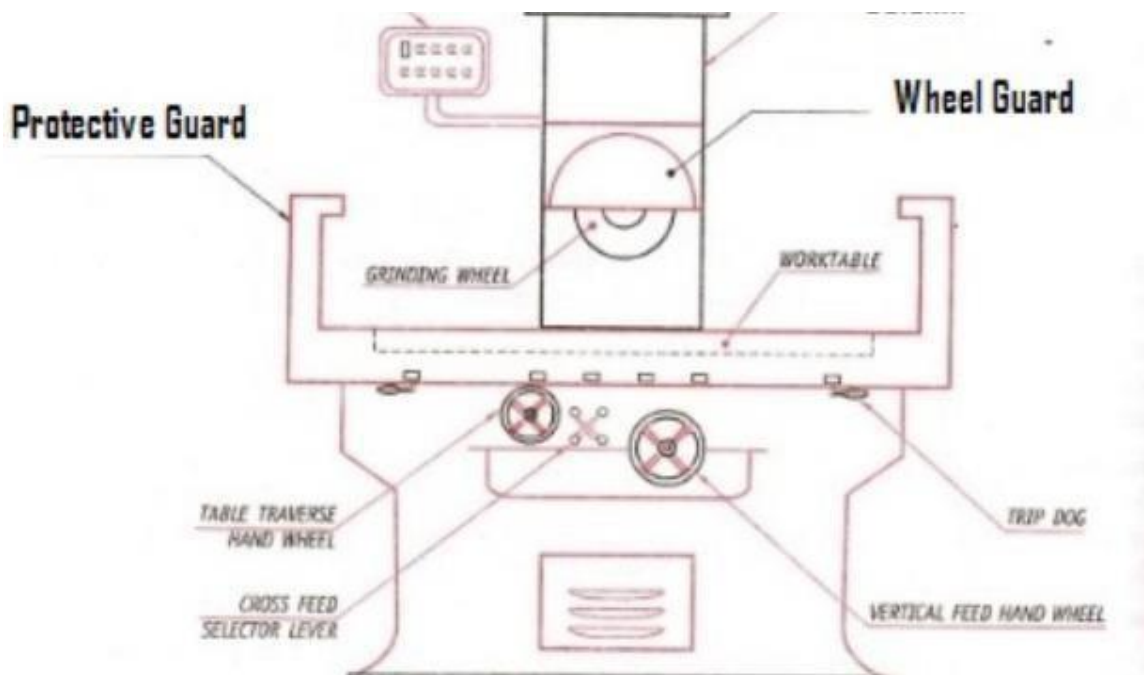

PRECAUTIONS:

1. Coolant usage is compulsory as the speeds employed are very high and continuous application of coolant is necessary for ductile materials like-steel etc.
2. The grinding tools are first dressed properly.
3. Care has to be taken so as to maintain the right feed of the material.
4. Work-wheel interface zone is to be flooded with coolant
5. Dressing of grinding wheel to be done before commencement of cutting action, intermittent dressing also to be done if wheel is loaded.

RESULT:

APPLICATIONS :

1. Cylindrical grinding process is used for grinding the outer surface of cylindrical object
2. Center less grinding process is used for preparing the transmission bushing, shouldered pins and ceramic shafts for circulator pumps.
3. Internal grinding process is used for finishing the tapered, straight and formed holes precisely.
4. There are few special grinders used for sharpen the milling cutters, taps, other various machine cutting tool cutter and reamers.

ADVANTAGES:

1. Investment is less
2. Working principle and operation is simple
3. It does not require additional skills
4. Surface finishing will be approximate 10 times better as compared to milling and turning process of machining.
5. Dimensional accuracy will be quite good
6. Grinding process could be performed on hardened and unhardened workpiece also

VIVA QUESTIONS:

- 1.State the purpose of grinding?
- 2.What is the function of cutting fluids?
- 3.What are the properties of cutting fluid?
- 4.What are causes of wear?

EXP 8 CYLINDRICAL GRINDING

Aim: To Perform Cylindrical Grinding Operation On The Given Work Piece.

MATERIALS REQUIRED: mild steel specimen.

MACHINE REQUIRED: cylindrical grinding machine

MEASURING INSTRUMENTS: Vernier calipers, Micrometer.

CUTTING TOOLS: Diamond point dressing block

WORK HOLDING FIXTURES: Magnetic chuck

MISCELLANEOUS TOOLS:

Wire brush (for cleaning the formed chips), Lubricant (coolant)

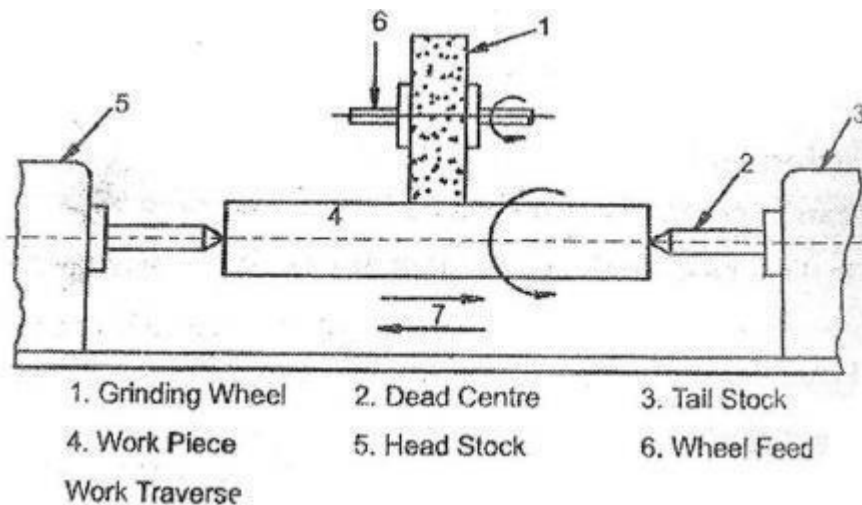

Experimental Diagram Cylindrical Grinding:

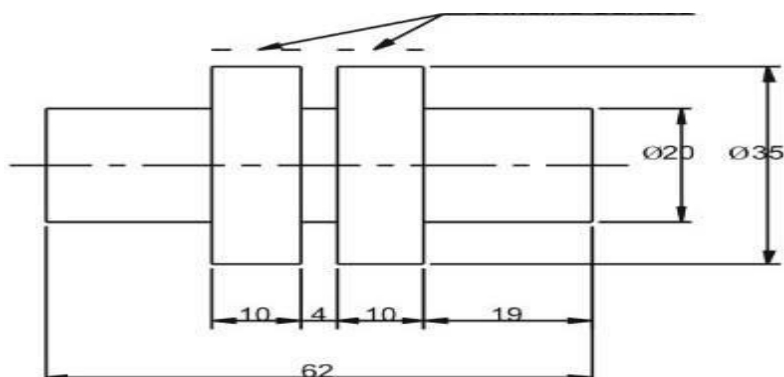

All dimensions are in mm

PROCEDURE:

1. Work piece is mounted on magnetic table, so that the line along face of grinding wheel coincides with the edge of work piece.

2. Depth of cut is given to work piece by down feed hand wheel.
3. The work piece reciprocates under wheel and the table feeds axially between passes to produce flat surface and to get required size of work piece.

PRECAUTIONS :

1. Coolant usage is compulsory as the speeds employed are very high and continuous application of coolant is necessary for ductile materials like-steel etc.
2. The grinding tools are first dressed properly.
3. Care has to be taken so as to maintain the right feed of the material.
4. Work-wheel interface zone is to be flooded with coolant
5. Dressing of grinding wheel to be done before commencement of cutting action, intermittent dressing also to be done if wheel is loaded.

RESULT**APPLICATIONS :**

1. Cylindrical grinding process is used for grinding the outer surface of cylindrical object
2. Center less grinding process is used for preparing the transmission bushing, shouldered pins and ceramic shafts for circulator pumps.
3. Internal grinding process is used for finishing the tapered, straight and formed holes precisely.
4. There are few special grinders used for sharpen the milling cutters, taps, other various machine cutting tool cutter and reamers.

EXP 9 MAKING INTERNAL SPLINES USING SLOTTING MACHINE AIM:

To make a slot in cast iron pulley as per the sketch given dimensions. **MATERIALS**

REQUIRED: mild steel, aluminum.

MACHINE REQUIRED: slotting machine

MEASURING INSTRUMENTS: Vernier calipers slip gauges.

CUTTING TOOLS: H.S.S.Tool bit of the required slot size.

PROCEDURE:

1. Fix the work piece in the head stock chuck firmly
2. Turning tool is fixed in the tool post and centering is to be done
3. Turn the job to get a Diameter of required length
4. Facing is to be done on one side of the job
5. Drill bit of 8 mm diameter is fixed on tail stock and centering of work piece is to be done by feeding through tail stock.
6. Drill bit of 25 mm diameter is fixed in tail stock
7. Drill through a hole of 25 mm diameter in the work piece feeding the tail stock.
8. Boring tool is the fixed in tool post to perform boring operation to get a hole of required diameter
9. Fit the job in reverse position in the chuck
10. Facing of other side of the work piece is to be done to get the required length of the job
11. Drilled work piece is fixed on slotting machine.
12. A slot of required depth is made

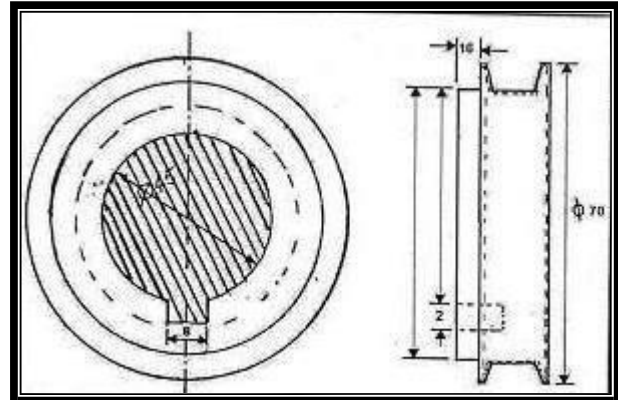
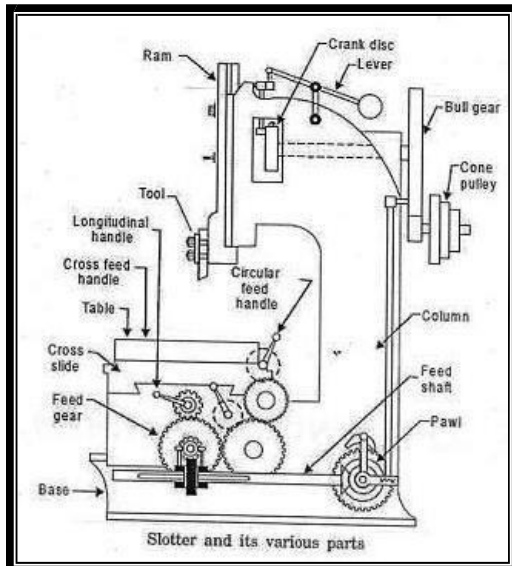

Parts of slotting Machine

Experimental Diagram:

All Dimensions are in mm

PRECAUTIONS:

1. Choose proper feed and depth of cut.
2. Feed should be controlled to avoid any damage to the cutting tool
3. Lock the index table before starting the operation.
4. Care has to be taken so as to maintain the right feed of the material.
5. Work-wheel interface zone is to be flooded with coolant
6. Dressing of grinding wheel to be done before commencement of cutting action, intermittent dressing also to be done if wheel is loaded.

RESULT:

APPLICATIONS:

Slotting machines are used to cut grooves and slots in shapes and holes while additionally smoothing the worked surface. Because they are more economical at high production rates due to reproducibility and consistency, slotters are generally used in high volume operations. They are used in steel rolling mills, paper mills, power plants, ship building, textile factories, tool rooms, and repair shops.

